

HeatGuard™ SharkBite® 4-in-1

Scope of Use/Specification Sheet

RMC's HeatGuard SharkBite® 4-in-1 is a pre-built tempering valve assembly with integrated inlet fittings that allow for quick installation and simplified valve maintenance for an entire house, building, or system.



TVX1505

Product List

Model	Description
TVX1505	SharkBite 4-in-1 Upwards - 16mm
TVX1504	SharkBite 4-in-1 Downwards - 16mm
TVX2005	SharkBite 4-in-1 Upwards - 20mm
TVX2004	SharkBite 4-in-1 Downwards - 20mm

Description

RMC's HeatGuard is a tempering valve that mixes hot water with cold water to deliver tempered water at a constant temperature throughout an entire house, building or system. HeatGuard is suitable for tempering the hot water supply to sanitary devices intended for personal hygiene, where outlet temperatures must not exceed 50°C (to AS 4032.2). HeatGuard is compatible with most storage water heaters.

RMC's HeatGuard SharkBite® 4-in-1 combines the HeatGuard tempering valve with 4-in-1 inlet fittings and genuine SharkBite® connections. The 4-in-1 inlet fittings include isolation valves, strainers, non-return valves and test ports.

The HeatGuard SharkBite® 4-in-1 is available in 16mm or 20mm configurations, with the valves pre-fitted and orientated either upwards or downwards.

Features and Benefits

- Genuine SharkBite® connections
- Valve and fittings are supplied fully assembled
- 4-in-1 inlet fittings incorporate a ball valve, strainer, non-return valve and test port
- Strainers protect valve from impurities in the water supply
- Non-return check valves eliminate backflow contamination
- Inline isolation valves provide for simpler installation and maintenance
- Tamper proof adjustment – special key eliminates chances of accidental adjustment
- Dezincification resistant
- Meets Australian Standard for potable water supply
- Individually tested and calibrated to ensure high quality and performance
- Compliant to the Lead Free requirements of the National Construction Code Volume Three

Materials

Body	Forged Lead Free DZR Brass
Internal Components	Lead Free DZR Brass
Seals	Viton®
Springs	Stainless Steel
Piston	Polysulphone
Fittings	Lead Free DZR Brass
Strainers	Stainless Steel
Non-Return Cartridges	Acetal

HeatGuard SharkBite® 4-in-1

Technical Specifications

Cold water supply temperature	5°C to 30°C
Hot water supply temperature	60°C to 90°C ¹
Maximum supply pressure	1600kPa
Supply pressure imbalance, dynamic (at time of commissioning)	2:1 maximum ²
Optimum outlet temperature range	40°C to 50°C ³
Factory set temperature	See notes ⁴
Temperature control	± 3°C ⁵
Minimum temperature differential (between hot supply and outlet temperature)	15°C ⁶
Minimum flow rate	4L/min

Notes

- AS/NZS 3500.4 Clause 1.9.1 requires the minimum hot water storage temperature to be 60°C. Not for use with steam.
- The maximum permitted ratio of supply pressures, under dynamic (flow) conditions. For optimum performance it is recommended that the hot and cold pressures at commissioning are as close as possible to equal.
- For applications outside the requirements of AS/NZS 3500 and AS 4032.2, it is possible to set the valve as high as 55°C or as low as 35°C, depending on site conditions.
- Must be commissioned on-site to achieve desired outlet temperature.
- Tested to AS 4032.2 between 40°C and 50°C.
- This is the minimum difference required to shut-off outlet flow in the event of cold supply failure in accordance with AS 4032.2, providing the valve is set between 40°C and 50°C.

Application

RMC's HeatGuard SharkBite® 4-in-1 is a tempering valve for use in hot water distribution systems. Fitting the valve at the hot water source ensures the delivery of constant tempered water throughout the system.

DO NOT USE on steam supplied systems, or in place of a TMV (AS 4032.1) valve.

Dimensions

Size	A	B	C	D	E
TVX1505	190	58	104	210	152
TVX1504	190	58	104	152	-
TVX2005	190	58	109	219	155
TVX2004	190	58	109	155	-

Note: All measurements in mm unless otherwise stated.

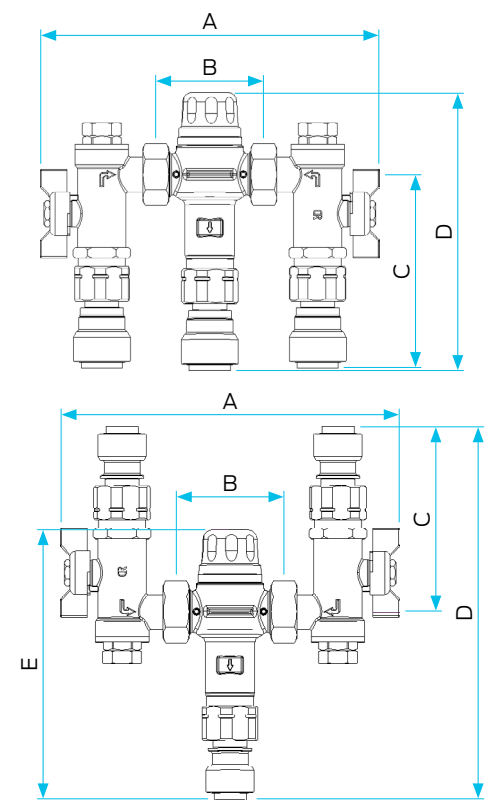

HeatGuard SharkBite® 4-in-1

Flow Characteristics

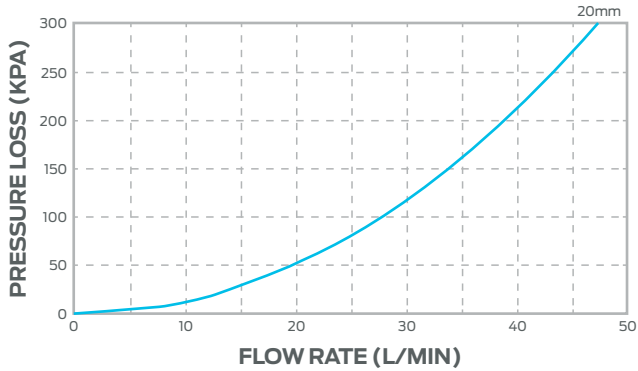

Installation

Installation is subject to the requirements of the applicable regulatory authority, the National Construction Code Volume Three – Plumbing Code of Australia, associated reference standards as applicable at the time and AS/NZS 3500. This product is compliant to the Lead Free requirements of the National Construction Code Volume Three. For further Scope of Use, please visit www.rmc.com.au/resources.

Standards and Approvals



Lead Free

AS 4032.2
WMKA1593

Warranty

Reliance Worldwide Corporation (Aust.) Pty. Ltd. (RWC) will either replace or repair any defective goods where the defect arose as a result of manufacture within the warranty period. You may contact RWC at the phone number, address or e-mail shown below for further information or to make a claim.

Visit www.rmc.com.au/warranty to view the warranty statement in full and for further important information.