

Water Flexible Hose Connectors

Scope of Use / Specification Sheet

The RMC range of F&F Water Flexible Hose Connectors are available in lengths from 150mm – 1500mm.

Lined with 8mm PEX and wrapped in stainless steel braid, they are suitable for hot and cold, potable water applications.

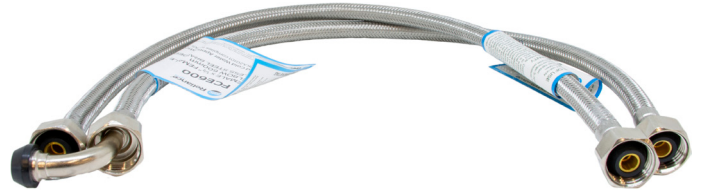

Product Code

Size	Connection	Product Code
150mm	Straight	FCX03
225mm	Straight	FCX04
300mm	Straight	FCX05
	Elbow	FCX08
450mm	Straight	FCX06
	Elbow	FCX09
600mm	Straight	FCX07
	Elbow	FCX10
1000mm	Straight	FCX01
1500mm	Straight	FCX02

Features and Benefits

- Suitable for hot and cold water
- Stainless steel braided
- 8mm PEX lined
- Female hex rubber cone seal
- Brass captive nuts for ease of installation
- Nickel plated finish on brass connections
- Available in straight and elbow
- 10 year warranty

Installation

Installation is subject to the requirements of the applicable regulatory authority, the National Construction Code Volume Three – Plumbing Code of Australia, associated reference standards as applicable at the time and AS/NZS 3500. This product is compliant to the Lead Free requirements of the National Construction Code Volume Three. For further Scope of Use, please visit www.rmc.com.au/resources.

Warranty

Reliance Worldwide Corporation (Aust.) Pty. Ltd. (RWC) will either replace or repair any defective goods where the defect arose as a result of manufacture within the warranty period. You may contact RWC at the phone number, address or e-mail shown below for further information or to make a claim.

Visit www.rmc.com.au/warranty to view the warranty statement in full and for further important information.

Standards and Approvals



Lead Free

AS/NZS 3499
WMKA 20101

Flexible Hose Connectors

Materials

1	HEX Nut	Brass
2	Conical Washer	EPDM
3	Core	Lead-free DZR Brass
4	Crimp Sleeve	SS304 Stainless Steel
5	Braided Hose	SS304 Stainless Steel
6	Inner Tube	Cross Linked Polyethylene (PEX)

Technical Specifications

Temperature range	5°C – 70°C
Maximum inlet pressure	1400kPa

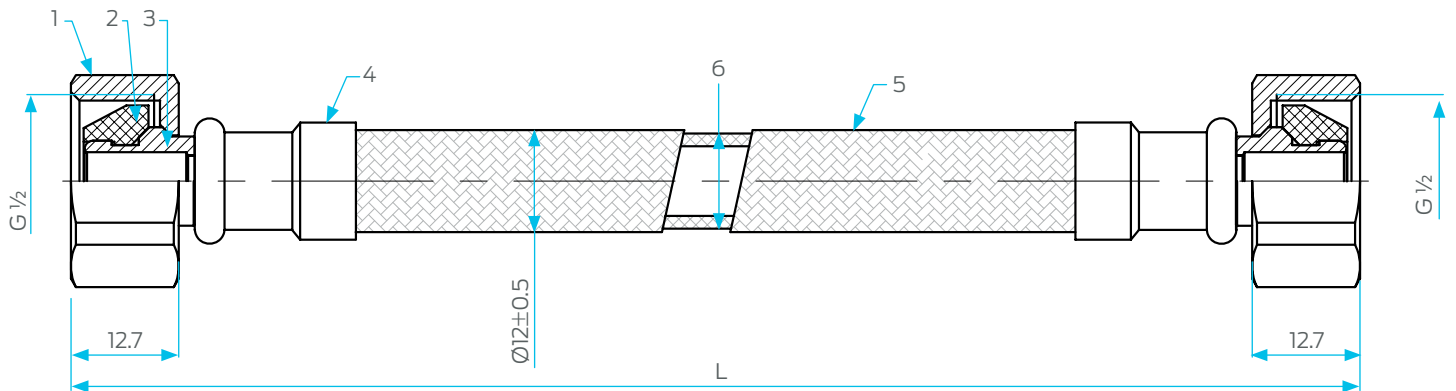

Installation

- This product should be installed by a licensed plumber
- For indoor use only
- Not to be connected directly to a hot water heater
- Connectors are designed for applications above ground with easy access, and are not to be submerged
- It is the responsibility of the installer to ensure the suitability of the connector for the application
- This product is only to be used on potable or Class A recycled water
- Do not twist, stretch or excessively bend the connector, and it should be free from other objects (*Refer to diagrams on following page*)
- Prior to installing ensure that all threads are clean and that the seals are undamaged
- Ensure that there are no leaks after installation
- Tighten to 5Nm - do not over tighten
- Temperature range: 5°C – 70°C
- Maximum inlet pressure: 1400kPa

Installation is subject to the requirements of the applicable regulatory authority, the National Construction Code Volume Three – Plumbing Code of Australia, associated reference standards as applicable at the time and AS/NZS 3500.

Flexible Hose Connectors

Correct Installation

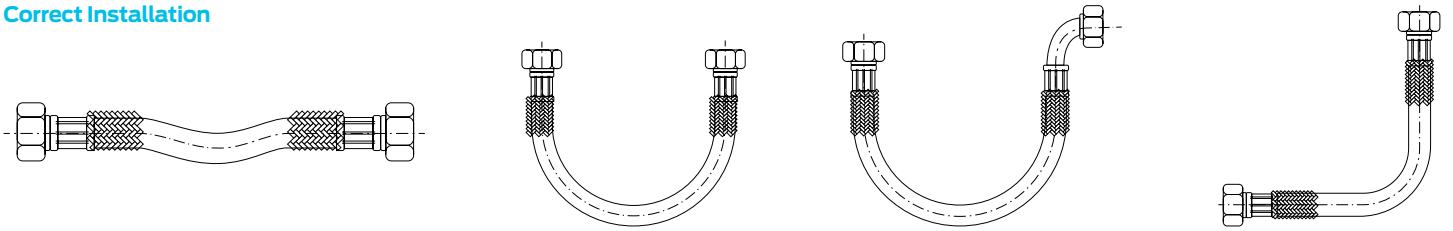

Incorrect Installation

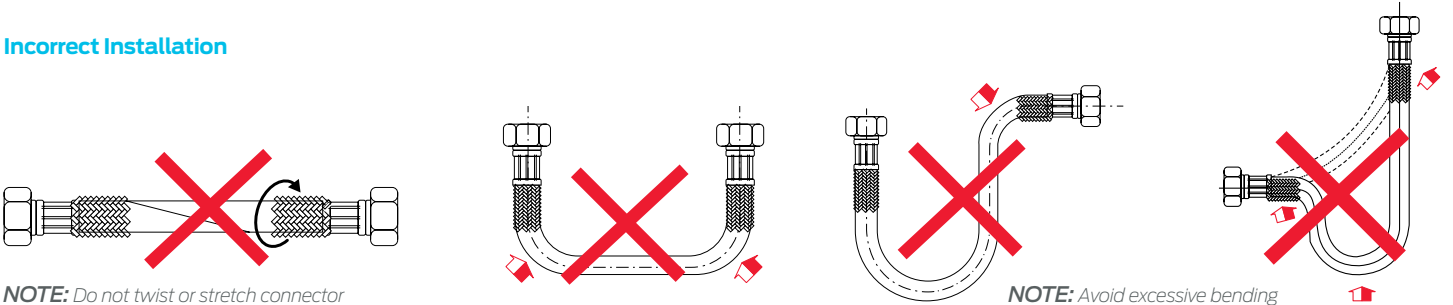

NOTE: Do not twist or stretch connector

NOTE: Avoid excessive bending

